

ELECTRIC BATTERY HOIST



Aid TÜV tested

General Description:

Aid in conformity to the Standard EN ISO 10535.

Structure made with powder varnished steel. Lifting by electric actuator equipped with mechanical disengage for the emergency descent, developed to have the best performance and the less possible energy consumption; speed following rule EN60535. The actuator has only push effect to avoid squeezings during the descent of the user in case of carelessness of the assistant. The handset is connected to the power module by spiral cable, with control buttons with "constant pressure".(EN ISO 10535).

The hoist is equipped with power module having emergency button, acoustic indicator for battery discharged, visual indicator of the fault, overcharge and overfunctioning, additional button for descent and display indicating the battery charge status .

Removing battery pack 24V DC maintenance free.

Inner automatic charger with led for charge status. The electric system conforms to the rules EN60601-1 and UL2601. Handle for moving. To the hanger is possible to apply all the type of slings available in our programme . Adjustable sling available in different sizes made of synthetic material easy to be clean, as specified in the technical sheet . Base with legs opening by lever to allow the front access for the transfer from the wheelchair, from the bathtub, from the wc ecc. Range of lift from the floor until 121 cm. 4 twin wheels at the base, the rear ones with footbrake which allows the passage under the beds and the bases following Rule UNI EN 1970. Reducible frame for easy transport and storage. Load capacity 150 Kg. Autonomy: approx. 40 complete cycles with 150 Kg of load (lifting at the maximum height and return to the floor at intervals of 18min each 2 minutes of exercise). Antitrauma caps and bumpers at the 4 ends of the base.

All the materials used are biocompatible and hypoallergenic.

COD. ISO 12.36.03.006

Technical data of the product:

Colour:	Light grey
Structure:	Powder varnished steel
Dimensions (cm):	127x60x200h max
Volume (m³):	0,22
Weight (Kg):	41,7
Weight w/package. (Kg):	46
Antistatic:	No
Disposable:	No
Fire resistant:	Yes
Use manual	With the aid

Statement of conformity included in the use manual. 

Commercial informations:

Document date:	14/02/2013
CND code	Y123603
RDM code	108523/R
Code ISO 9999:	12.36.03.006

warranty:

Moving/contact parts, electric and electronic components	12 months
Frame	36 months

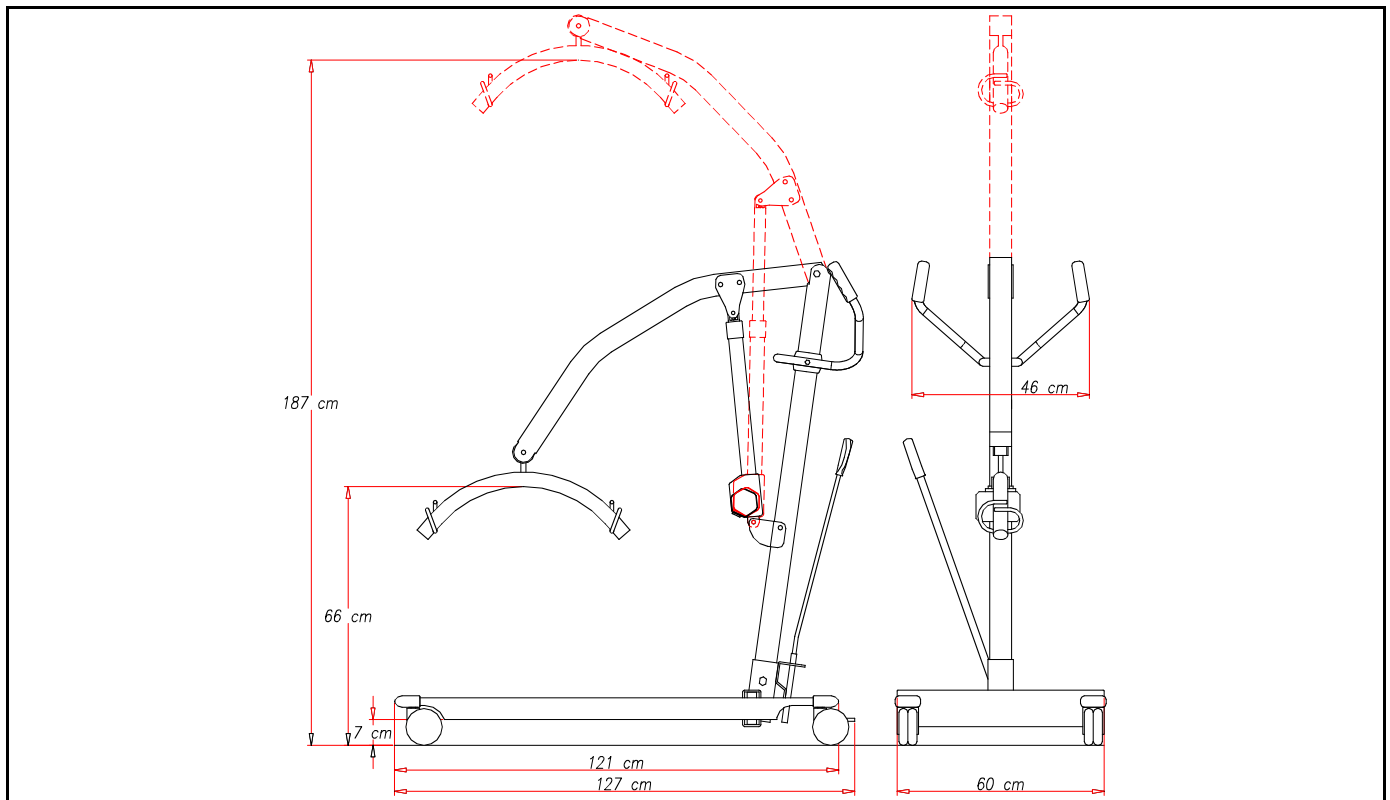

LIST OF OPTIONS:

13.07	DYNAMOMETER WITH HANGER	
15.94	STRETCHER SLING	
15.95	TETRAPLEGICS SLING WITH HEAD SUPPORT	
15.95A	SLING FOR BILATERAL AMPUTATED	
15.95A DX/SX	SLING FOR RIGHT/LEFT AMPUTATED	
15.95E	EVACUATION SLING	
15.95PL	TETRAPLEGICS SLING WITH HEAD STRAP	
15.97	STANDARD SLING	
15.99	ELECTRIC OPENING LEGS	